



- 
**Materiales/** • Estructura y tablonces de Pino Rojo del Norte de 45 mm de espesor, tratado en autoclave a nivel P4.
- 
**Materials/** • 45 mm thick North Pine Wood slats and structure, P4 vacuum pressured treated.
- 
**Matériaux/** • Structure et planches en pin rouge du Nord 45 mm d'épaisseur, autoclave niveau P4.

## MONTAJE

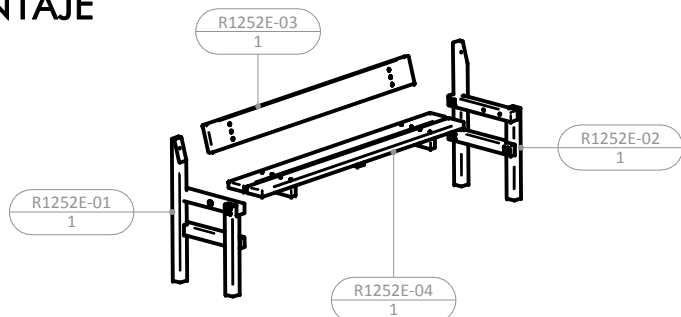

FIJACIÓN

FIXATION

FIXATION

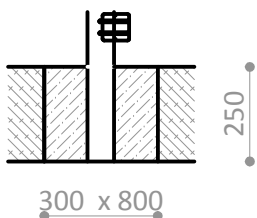

x2

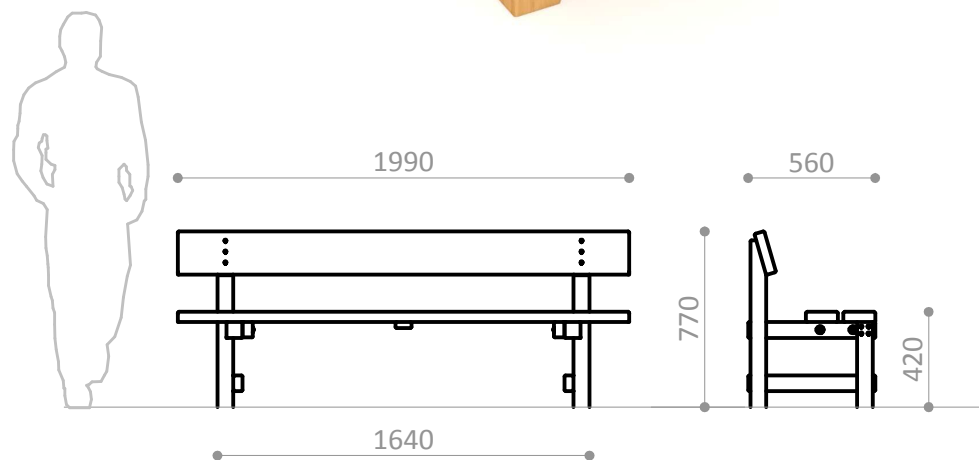

Industrias Agapito se reserva el derecho a modificar sin previo aviso los elementos descritos en este documento.  
Industrias Agapito reserves the right to change the items described in this document without prior notice.  
Industrias Agapito se réserve le droit de modifier à tout moment et sans préavis les éléments décrits dans le présent document.



